

This Guide to Quantities is only applicable to Data Sheets E120 and E130.

Specification for Individual Panels

	Weatherfold 4s 50	Weatherfold 4s 100
Track System	E120	E120
Refer to Data Sheet		
Max Panel Height	3000mm	3300mm
Max Panel Weight	50kg	75/100kg
Max Panel Width	1000mm	1000mm
Min Panel Thickness	35mm	35mm
Max Number of Panels	8 each direction	8 each direction

2 Panel Unit

	Quantities	Product Codes	
Track	1	180-A20	250-A20
Pivot Set	1	BWS1-100H	BWS1-100H
Hinge Handle Set	1	BW3-100H	BW3-100H
End Hanger Set	1	BWS2-50SH	BWS2-100SH
Flush Bolt Top	1	456*	456*
Flush Bolt Bottom	1	456E*	456E*
Channel	1	94PPA-A20	94PPA-A20

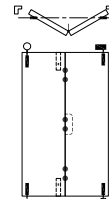

3 Panel Unit

	Quantities	Product Codes	
Track	1	180-A30	250-A30
Pivot Set	1	BWS1-100H	BWS1-100H
Offset Hinge Handle Set	1	BW7-100H	BW7-100H
Intermediate Hanger Set	1	BWS4-50SH	BWS4-100SH
Flush Bolt Top	1	456*	456*
Flush Bolt Bottom	1	456E*	456E*
Channel	1	94PPA-A30	94PPA-A30

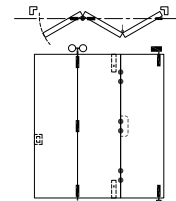

4 Panel Unit

	Quantities	Product Codes	
Track	1	180-A40	250-A40
Pivot Set	1	BWS1-100H	BWS1-100H
Offset Hinge Handle Set	2	BW7-100H	BW7-100H
Intermediate Hanger Set	1	BWS4-50SH	BWS4-100SH
End Hanger Set	1	BWS2-50SH	BWS2-100SH
Flush Bolt Top	2	456*	456*
Flush Bolt Bottom	2	456E*	456E*
Channel	1	94PPA-A40	94PPA-A40

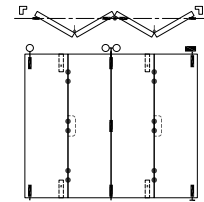

4 Panel Unit 'Floating'

	Quantities	Product Codes	
Track	1	180-A40	250-A40
Offset Hinge Handle Set	2	BW7-100H	BW7-100H
Intermediate Hanger Set	1	BWS4-50SH	BWS4-100SH
End Hanger Set	2	BWS2-50SH	BWS2-100SH
Flush Bolt Top	2	456*	456*
Flush Bolt Bottom	2	456E*	456E*
Channel	1	94PPA-A40	94PPA-A40

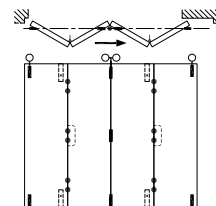

2+2 Panel Unit

	Quantities	Product Codes	
Track	1	180-A40	250-A40
Pivot Set	2	BWS1-100H	BWS1-100H
Hinge Handle Set	2	BW3-100H	BW3-100H
Hanger Set - Meeting	1	BWS8-50S	BWS8-100S
Flush Bolt Top	2	456*	456*
Flush Bolt Bottom	2	456E*	456E*
Channel	1	94PPA-A40	94PPA-A40

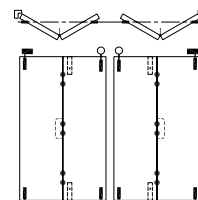

5 Panel Unit

	Quantities	Weatherfold 4s 50 Product Codes	Weatherfold 4s 100 Product Codes
Track	1	180-A60	250-A60
Pivot Set	1	BWS1-100H	BWS1-100H
Offset Hinge Handle Set	1	BW7-100H	BW7-100H
Intermediate Hanger Set	2	BWS4-50SH	BWS4-100SH
Hinge Handle Set	1	BW3-100H	BW3-100H
Flush Bolt Top	2	456*	456*
Flush Bolt Bottom	2	456E*	456E*
Channel	1	94PPA-A60	94PPA-A60

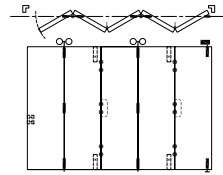

6 Panel Unit

	Quantities	Weatherfold 4s 50 Product Codes	Weatherfold 4s 100 Product Codes
Track	1	180-A60	250-A60
Pivot Set	1	BWS1-100H	BWS1-100H
Offset Hinge Handle Set	2	BW7-100H	BW7-100H
Intermediate Hanger Set	2	BWS4-50SH	BWS4-100SH
Hinge Handle Set	1	BW3-100H	BW3-100H
End Hanger Set	1	BWS2-50SH	BWS2-100SH
Flush Bolt Top	3	456*	456*
Flush Bolt Bottom	3	456E*	456E*
Channel	1	94PPA-A60	94PPA-A60

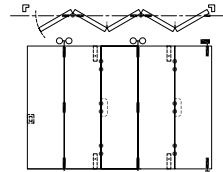

6 Panel Unit 'Floating'

	Quantities	Weatherfold 4s 50 Product Codes	Weatherfold 4s 100 Product Codes
Track	1	180-A60	250-A60
Offset Hinge Handle Set	2	BW7-100H	BW7-100H
Intermediate Hanger Set	2	BWS4-50SH	BWS4-100SH
Intermediate Hinge Set	1	BW3-100H	BW3-100H
End Hanger Set	2	BWS2-50SH	BWS2-100SH
Flush Bolt Top	3	456*	456*
Flush Bolt Bottom	3	456E*	456E*
Channel	1	94PPA-A60	94PPA-A60

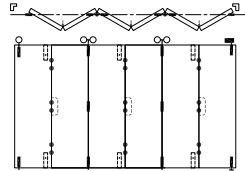

*Note, for aluminium systems refer to data sheet E130. On 2+2 units replace BWS8-50 or BWS8-100 with quantity 2 BWS2-50F or BWS2-100F respectively.

Replace 456 and 456RE flush bolts with 512 and 512E respectively. Alternatively top and bottom flush bolts can be replaced with dual point lock 286 in timber and aluminium.

Application

For residential and commercial folding systems where weatherproofing of the opening is required.

This section covers Weatherfold 4s 50 & 100 hardware suitable for non mortice timber applications.

For extra corrosion resistance, Weatherfold 4s is supplied with precision stainless steel bearings. Hangers are cast 316 marine stainless steel.

Panel Specification

Track System:	Weatherfold 4s 50	Weatherfold 4s 100
Max Panel Height	3000mm	3300mm
Max Panel Weight	50kg	100kg
Max Panel Width	1000mm	1000mm
Panel Thickness	35mm	35mm
Max Number of Panels	8 each direction	8 each direction

Hardware Specification

Track:	180	250
Material	Aluminium in Mill or Clear Anodised	
Standard Lengths	2000mm, 3000mm, 4000mm and 6000mm	

Hanger Sets:	BWS4-50SH	BWS4-100SH
Intermediate Hanger Set:	BWS4-50SH	BWS4-100SH
End Hanger Set:	BWS2-50SH	BWS2-100SH
Meeting Door Hanger Set - Rebate (includes 2 hangers)	BWS8-50	BWS8-100

Pivot Set:	BWS1-100H	BWS1-100H
	BWS1-100H	BWS1-100H

Jamb Pivot:	BW189H	BW189H
	BW189H	BW189H

Hinge Sets:	BW3-100H	BW3-100H
Hinge Handle Set	BW3-100H	BW3-100H
Offset Hinge Handle Set	BW7-100H	BW7-100H
Hinge Set	BW5-100H	BW5-100H
Offset Hinge Set	BW6-100H	BW6-100H

Channels:	94P	94P
Polypropylene	94P	94P
Polyprop Plus Support	94PPA	94PPA
Aluminium	94A	94A
Standard lengths	2000mm, 3000mm, 4000mm and 6000mm	

Accessories:	286T/35	286T/35
Lock Body - 35mm back set	286T/35	286T/35
Lock Body - 45mm back set	286T/45	286T/45
Non Locking Handle	286N	286N
Locking Handle 38-44mm panel	286L-30	286L-30
Locking Handle 44mm+ panel (Rod pack dependant on panel)	286L-30	286L-30
Flush Pull	401	401
Flush Bolt - 190mm	456	456
Flush Bolt - 450mm	456L	456L
Security Aligner	199SS	199SS
Frame Seal - White	AQ21W	AQ21W
Frame Seal - Brown	AQ21B	AQ21B
Door Seal - White	AQ63W	AQ63W
Door Seal - Brown	AQ63B	AQ63B
Track Seal	PS13B	PS13B

Finish options
 Dual Point Lock: (SS) Satin Stainless, (PS) Polished Stainless, (SN) Satin Nickel, (PBR) Powdercoat Black
 Hardware: (SS) Satin Stainless, (PS) Polished Stainless, (PB) PVD Brass.
 Flush bolts: (SN) Satin Nickel, (PVDB) PVD Brass.

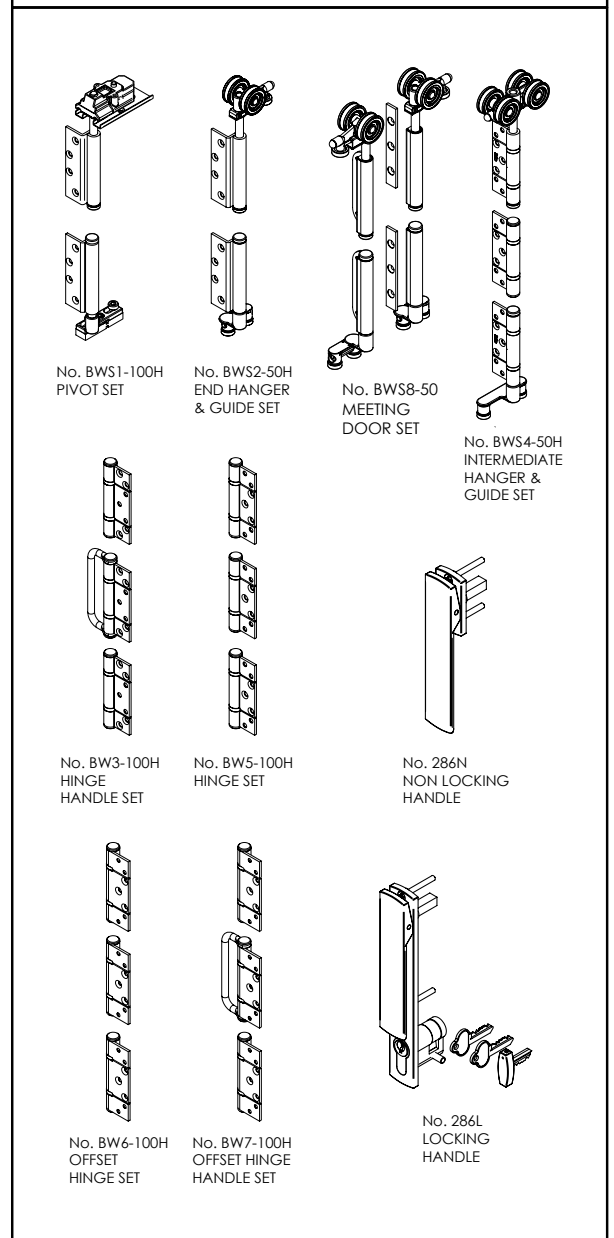
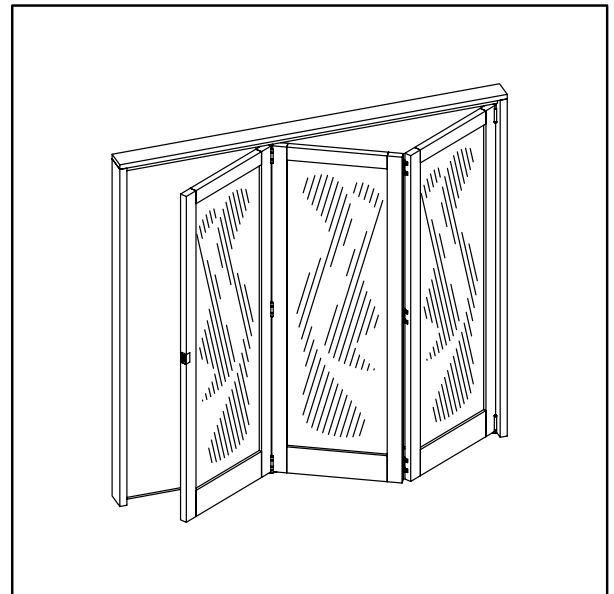

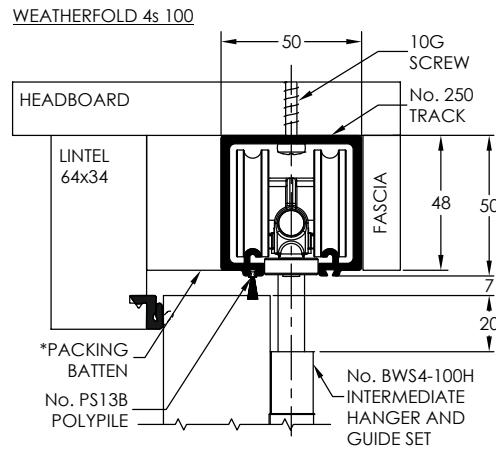
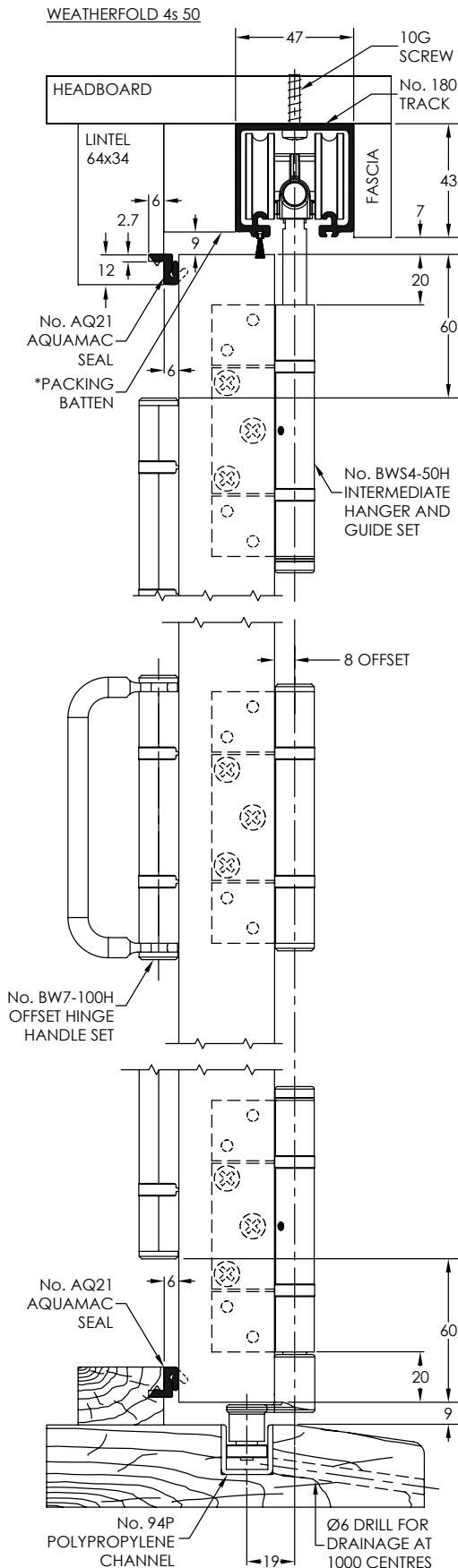

*PACKING BATTEN THICKNESS

50kg TRACK:
9.5mm LESS THAN
PANEL THICKNESS

100kg TRACK:
11mm LESS THAN
PANEL THICKNESS

4+0 PANEL OUTWARD OPENING SYSTEM - CLOSED
(SHOWN WITHOUT TRACK OR HEAD SECTION)

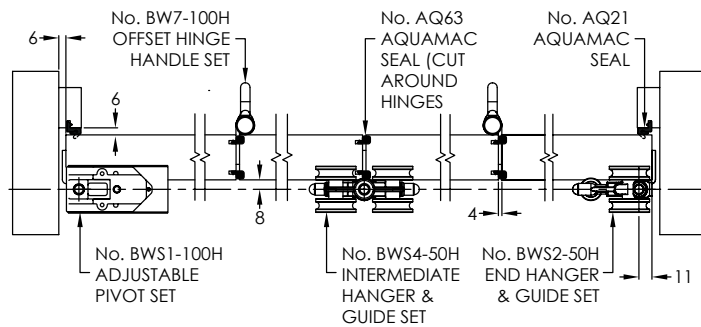

4+0 PANEL OUTWARD OPENING SYSTEM - OPEN
(SHOWN WITHOUT HEAD SECTION)

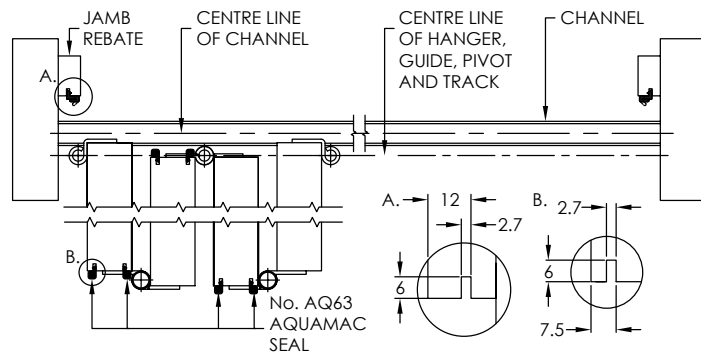

4+0 PANEL OUTWARD OPENING SYSTEM - CLOSED
(TYPICAL OUTSIDE ELEVATION)

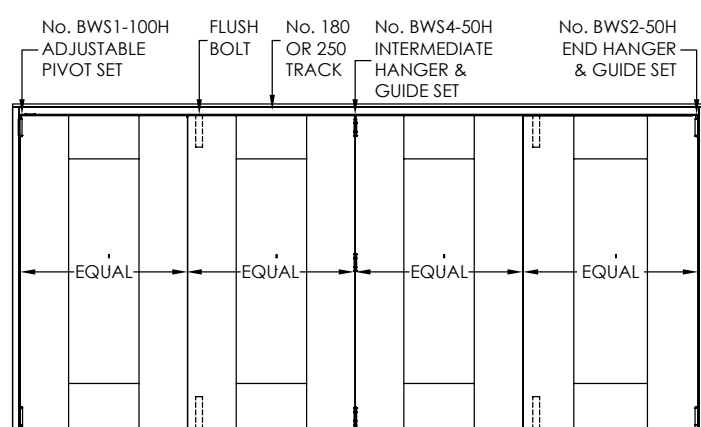

Application

For residential and commercial folding systems where weatherproofing of the opening is required.

This section covers Weatherfold 4s 50 & 100 hardware suitable for non mortice aluminium applications.

For extra corrosion resistance, Weatherfold 4s is supplied with precision stainless steel bearings. Hangers are cast 316 marine stainless steel.

Panel Specification

Track System:	Weatherfold 4s 50	Weatherfold 4s 100
Max Panel Height	3000mm	3300mm
Max Panel Weight	50kg	100kg
Max Panel Width	1000mm	1000mm
Panel Thickness	35mm	35mm
Max Number of Panels	8 each direction	8 each direction

Hardware Specification

Track:	180	250
Material	Aluminium in Mill or Clear Anodised	
Standard Lengths	2000mm, 3000mm, 4000mm and 6000mm	

Hanger Sets:		
Intermediate Hanger Set:	BWS4-50SH	BWS4-100SH
End Hanger Set:		
Face Fix	BWS2-50SF	BWS2-100SF
Edge Fix	BWS2-50SH	BWS2-100SH

Pivot Set:		
Face Fix	BWS1-100F	BWS1-100F
Edge Fix	BWS1-100H	BWS1-100H

Jamb Pivot:	BW189F	BW189F
-------------	--------	--------

Hinge Sets:		
Hinge Handle Set	BW3-100H	BW3-100H
Offset Hinge Handle Set	BW7-100H	BW7-100H
Hinge Set	BW5-100H	BW5-100H
Offset Hinge Set	BW6-100H	BW6-100H

Channels:		
Polypropylene	94P	94P
Polyprop Plus Support	94PPA	94PPA
Aluminium	94A	94A
Standard lengths	2000mm, 3000mm, 4000mm and 6000mm	

Accessories:		
Lever Furniture	288	288
Lock Body	286A	286A
Non Locking Body	286N	286N
Locking Handle (Rod pack dependant on panel)	286L-40	286L-40
Flush Pull	402	402
Flush Bolt - 400mm	512-400	512-400
Flush Bolt - 600mm	512-600	512-600
Flush Bolt - 900mm	512-900	512-900

Finish options
 Dual Point Lock: (SS) Satin Stainless, (PS) Polished Stainless, (SN) Satin Nickel,
 (PBR) Powdercoat Black
 Hardware: (SS) Satin Stainless
 Flush bolts: (SS) Satin Stainless

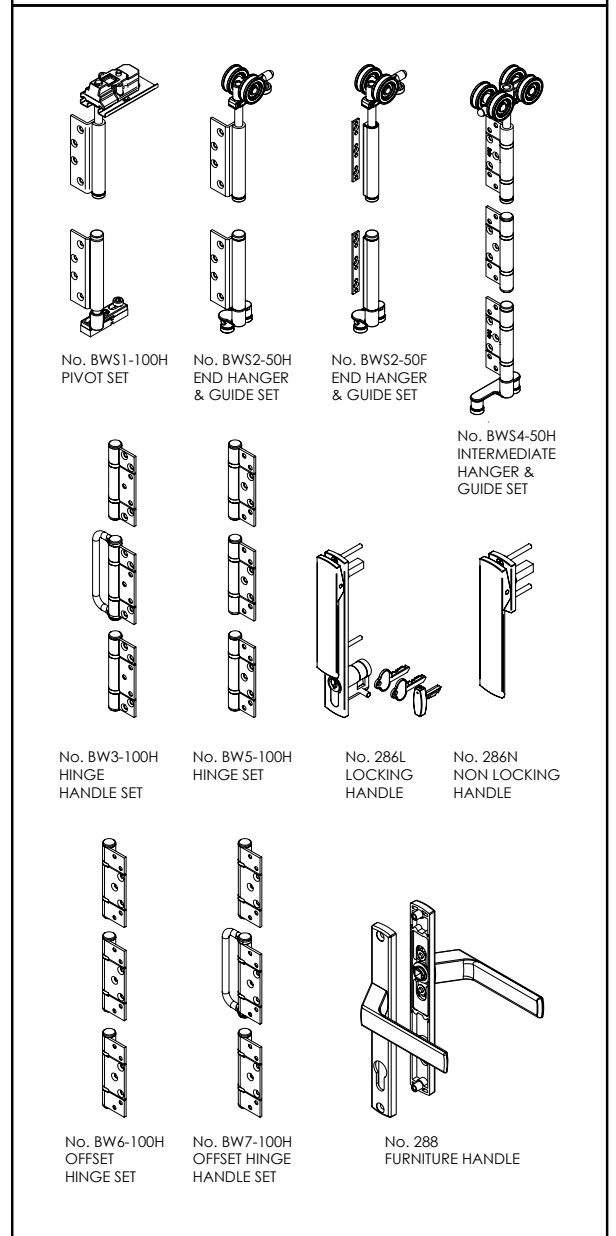
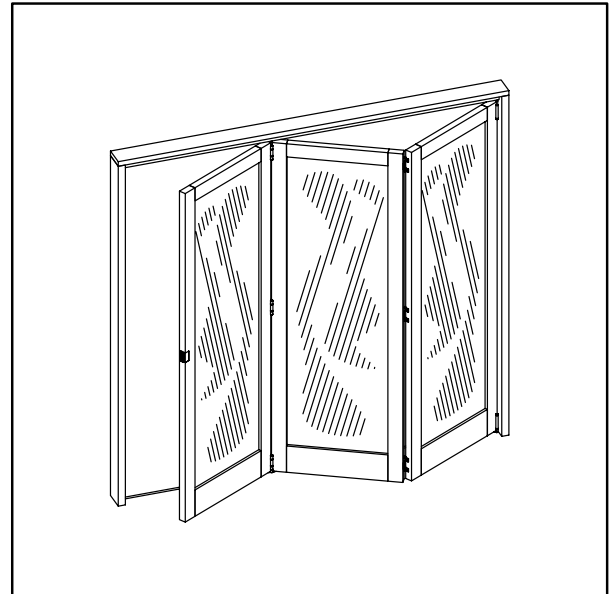

WEATHERFOLD 4s 50

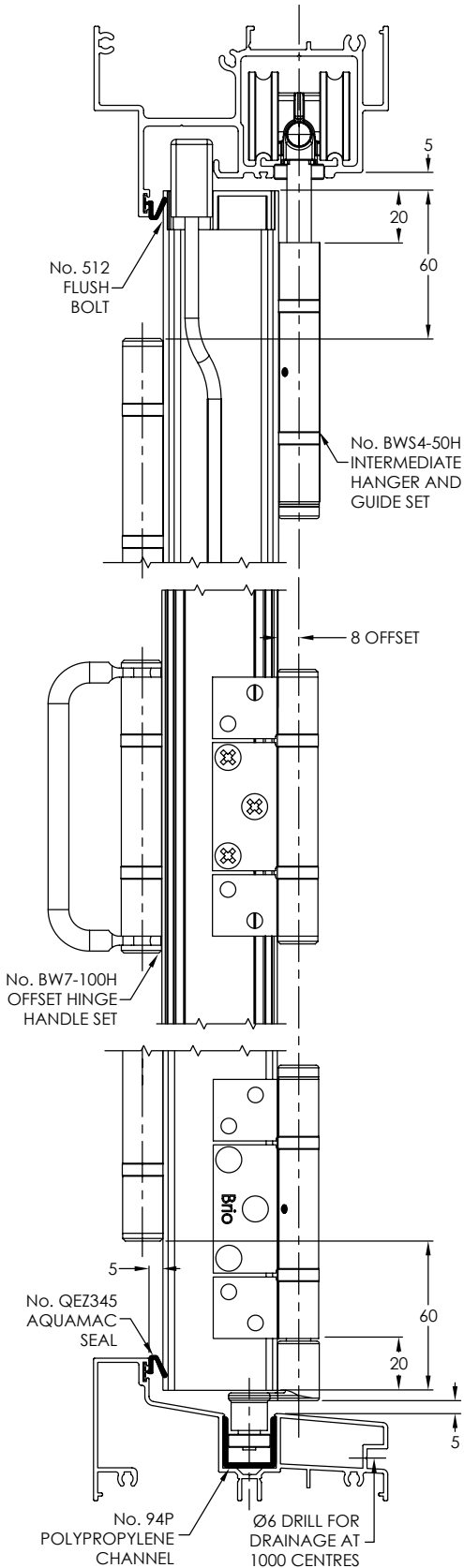

WEATHERFOLD 4s 100

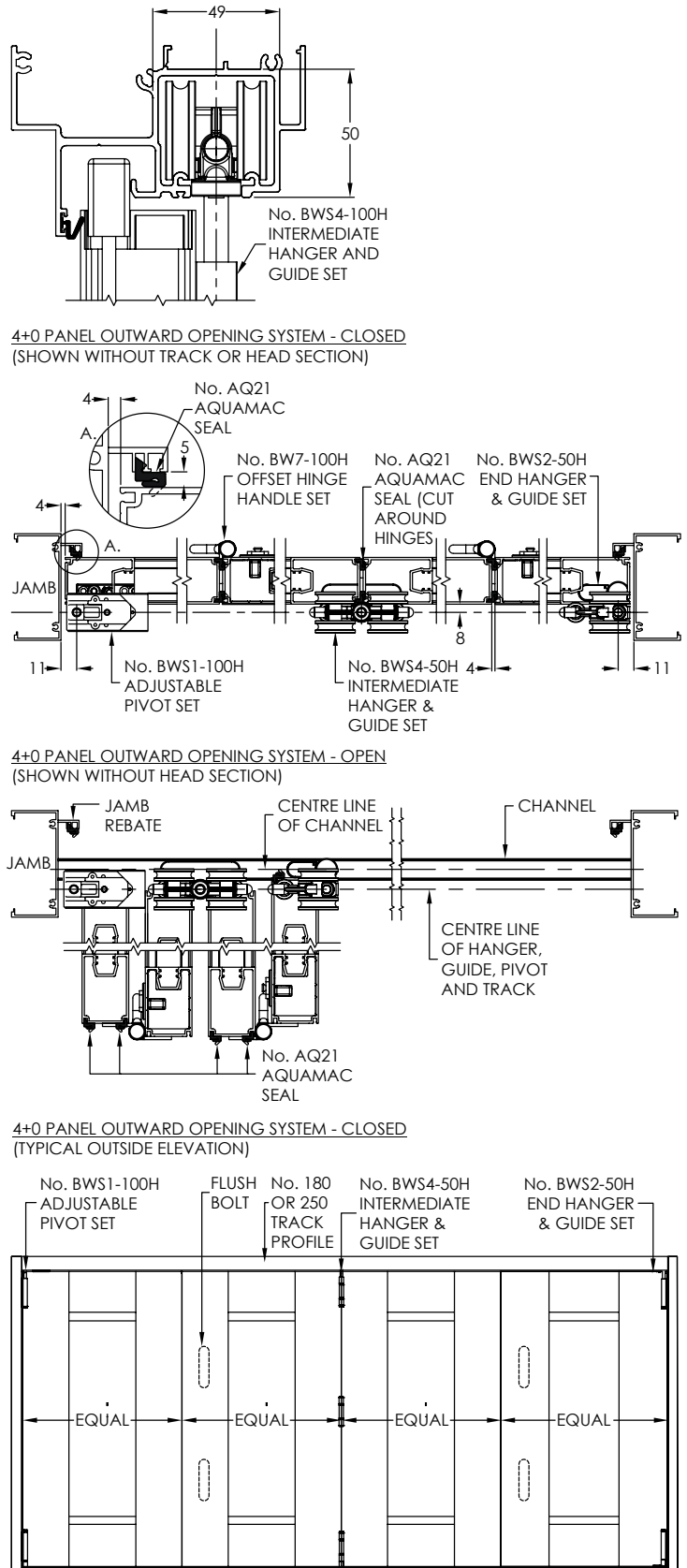

This Guide to Quantities is only applicable to Data Sheet E147.

Specification for Individual Panels

	Weatherfold 4s 50	Weatherfold 4s 100
Track System	E147	E147
Refer to Data Sheet		
Max Panel Height	3000mm	3300mm
Max Panel Weight	50kg	100kg
Max Panel Width	1000mm	1000mm
Min Panel Thickness	35mm	35mm
Max Number of Panels	8 each direction	8 each direction

2 Panel Unit

	Quantities	Product Codes	
Track	1	180-A20	250-A20
Pivot Set	1	BWS1-100M	BWS1-100M
Hinge Handle Set	1	BW3-100M	BW3-100M
End Hanger Set	1	BWS2-50SM	BWS2-100SM
Flush Bolt Top	1	456	456
Flush Bolt Bottom	1	456E	456E
Channel	1	94PPA-A20	94PPA-A20

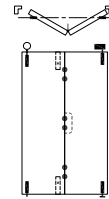

3 Panel Unit

	Quantities	Product Codes	
Track	1	180-A30	250-A30
Pivot Set	1	BWS1-100M	BWS1-100M
Offset Hinge Handle Set	1	BW7-100M	BW7-100M
Intermediate Hanger Set	1	BWS4-50SM	BWS4-100SM
Flush Bolt Top	1	456	456
Flush Bolt Bottom	1	456E	456E
Channel	1	94PPA-A30	94PPA-A30

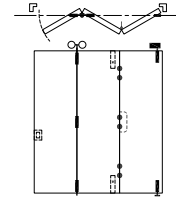

4 Panel Unit

	Quantities	Product Codes	
Track	1	180-A40	250-A40
Pivot Set	1	BWS1-100M	BWS1-100M
Offset Hinge Handle Set	2	BW7-100M	BW7-100M
Intermediate Hanger Set	1	BWS4-50SM	BWS4-100SM
End Hanger Set	1	BWS2-50SM	BWS2-(75/100)SM
Flush Bolt Top	2	456	456
Flush Bolt Bottom	2	456E	456E
Channel	1	94PPA-A40	94PPA-A40

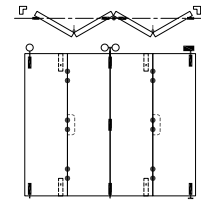

4 Panel Unit 'Floating'

	Quantities	Product Codes	
Track	1	180-A40	250-A40
Offset Hinge Handle Set	2	BW7-100M	BW7-100M
Intermediate Hanger Set	1	BWS4-50SM	BWS4-100SM
End Hanger Set	2	BWS2-50SM	BWS2-100SM
Flush Bolt Top	2	456	456
Flush Bolt Bottom	2	456E	456E
Channel	1	94PPA-A40	94PPA-A40

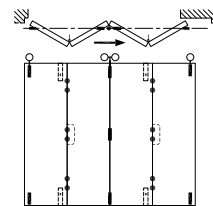

2+2 Panel Unit

	Quantities	Product Codes	
Track	1	180-A40	250-A40
Pivot Set	2	BWS1-100M	BWS1-100M
Hinge Handle Set	2	BW3-100M	BW3-100M
End Hanger Set	2	BWS2-50SM	BWS2-100SM
Flush Bolt Top	2	456	456
Flush Bolt Bottom	2	456E	456E
Channel	1	94PPA-A40	94PPA-A40

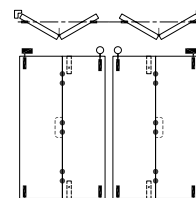

5 Panel Unit

	Quantities
Track	1
Pivot Set	1
Intermediate Hanger Set	2
Hinge Handle Set	1
Flush Bolt Top	2
Flush Bolt Bottom	2
Channel	1

Weatherfold 4s 50

Product Codes

180-A60
BWS1-100M
BWS4-50SM
BW3-100M
456
456E
94PPA-A60

Weatherfold 4s 100

250-A60
BWS1-100M
BWS4-100SM
BW3-100M
456
456E
94PPA-A60

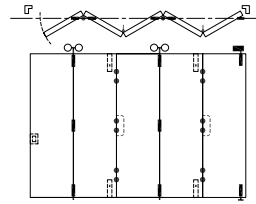

6 Panel Unit

	Quantities
Track	1
Pivot Set	1
Intermediate Hanger Set	2
Hinge Handle Set	3
End Hanger Set	1
Flush Bolt Top	3
Flush Bolt Bottom	3
Channel	1

Product Codes

180-A60
BWS1-100M
BWS4-50SM
BW3-100M
BWS2-50SM
456
456E
94PPA-A60

250-A60
BWS1-100M
BWS4-100SM
BW3-100M
BWS2-100SM
456
456E
94PPA-A60

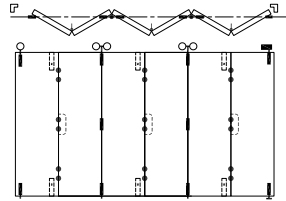

6 Panel Unit 'Floating'

	Quantities
Track	1
Intermediate Hanger Set	2
Offset Hinge Handle Set	2
Hinge Handle Set	1
End Hanger Set	2
Flush Bolt Top	3
Flush Bolt Bottom	3
Channel	1

Product Codes

180-A60
BWS4-50SM
BW7-100M
BW3-100M
BWS2-50SM
456
456E
94PPA-A60

250-A60
BWS4-100SM
BW7-100M
BW3-100M
BWS2-100SM
456
456E
94PPA-A60

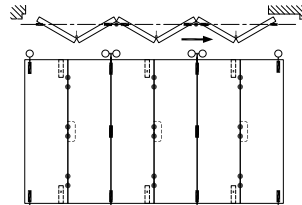

2 Additional Panels to Increase 5 or 6 Panels to 7 or 8 Panels

	Quantities
Track	1
Intermediate Hanger Set	1
Hinge Handle Set	1
Flush Bolt Top	1
Flush Bolt Bottom	1
Channel	1

Product Codes

180-A60
BWS4-50SM
BW3-100M
456
456E
94PPA-A20

250-A60
BWS4-100SM
BW3-100M
456
456E
94PPA-A20

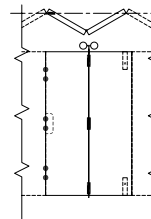

Application

For residential and commercial folding systems where weatherproofing of the opening is required.

This section covers Weatherfold 4s 50 & 100 Mortice Square Corner Hinge hardware for timber panels. The high-strength hinges are manufactured from 3mm thick stainless steel with square corners.

For extra corrosion resistance, Weatherfold 4s is supplied with precision stainless steel bearings. Hangers are cast 316 marine stainless steel.

Panel Specification

Track System:	Weatherfold 4s 50	Weatherfold 4s 100
Max Panel Height	3000mm	3300mm
Max Panel Weight	50kg	100kg
Max Panel Width	1000mm	1000mm
Panel Thickness	35mm	35mm
Max Number of Panels	8 each direction	8 each direction

Hardware Specification

Track:	180	250
Material	Aluminium in Mill or Clear Anodised	
Standard Lengths	2000mm, 3000mm, 4000mm and 6000mm	

Hanger Sets:		
Intermediate Hanger Set:	BWS4-50SM	BWS4-100SM
End Hanger Set:	BWS2-50SM	BWS2-100SM

Pivot Sets:	BWS1-100M	BWS1-100M
-------------	-----------	-----------

Jamb Pivot:	BW189M	BW189M
-------------	--------	--------

Hinge Sets:		
Hinge Handle Set	BW3-100M	BW3-100M
Offset Hinge Handle Set	BW7-100M	BW7-100M
Hinge Set	BW5-100M	BW5-100M
Offset Hinge Set	BW6-100M	BW6-100M

Channels:		
Polypropylene	94P	94P
Polyprop Plus Support	94PPA	94PPA
Aluminium	94A	94A
Standard lengths	2000mm, 3000mm, 4000mm and 6000mm	

Accessories:		
Flush Pull	401	401
Flush Bolt - 190mm	456	456
Flush Bolt - 450mm	456L	456L
Security Aligner	199SS	199SS
Frame Seal - White	AQ21W	AQ21W
Frame Seal - Brown	AQ21B	AQ21B
Door Seal - White	AQ63W	AQ63W
Door Seal - Brown	AQ63B	AQ63B
Track Seal	PS13B	PS13B

Finish options
 Hardware: (SS) Satin Stainless, (PS) Polished Stainless, (PB) PVD Brass.
 Flush bolts: (SN) Safin Nickel, (PVDB) PVD Brass.

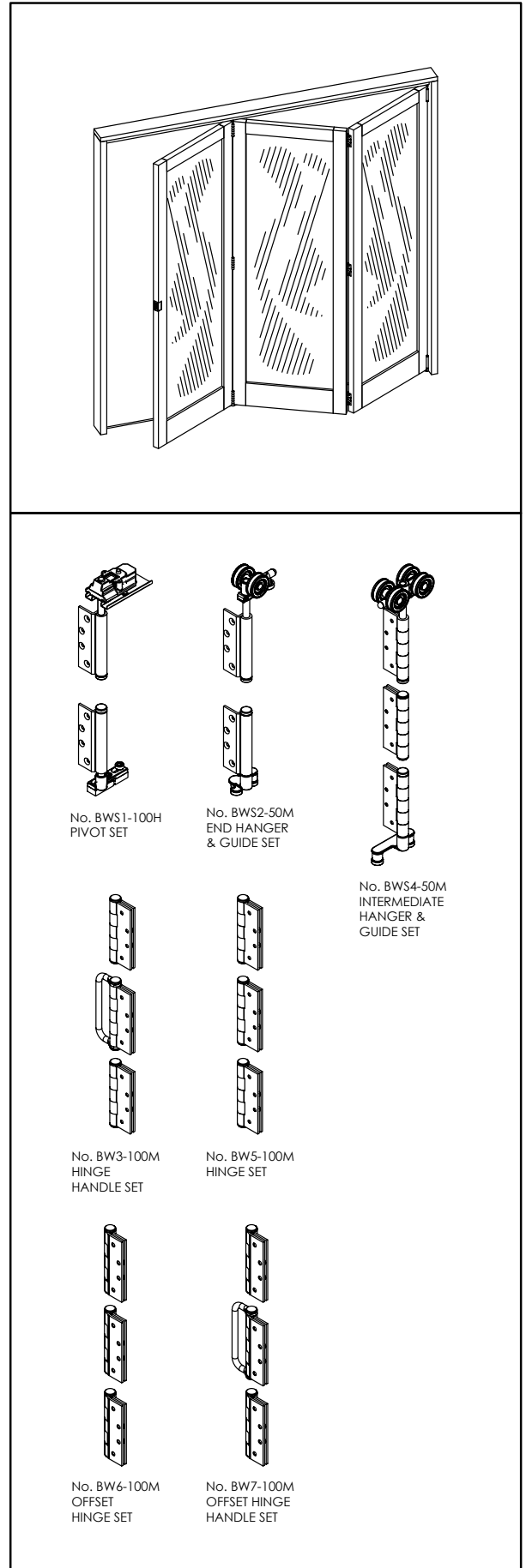

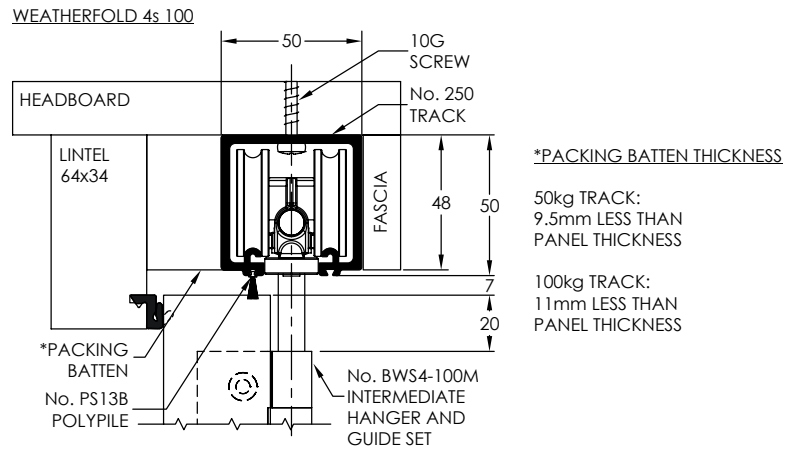
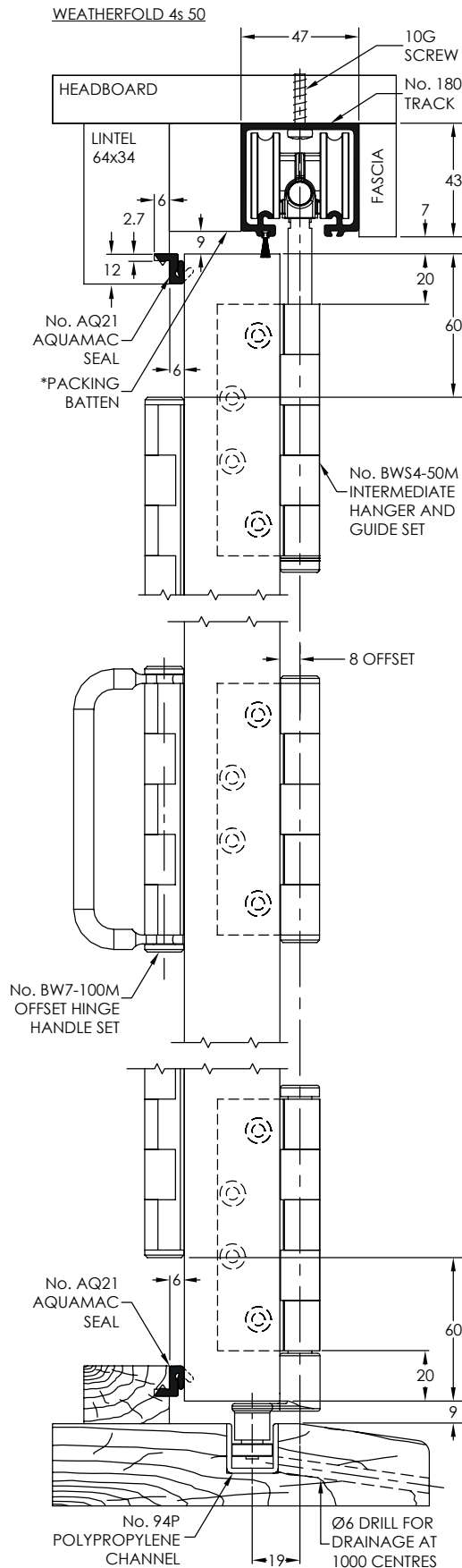

4+0 PANEL OUTWARD OPENING SYSTEM - CLOSED
(SHOWN WITHOUT TRACK OR HEAD SECTION)

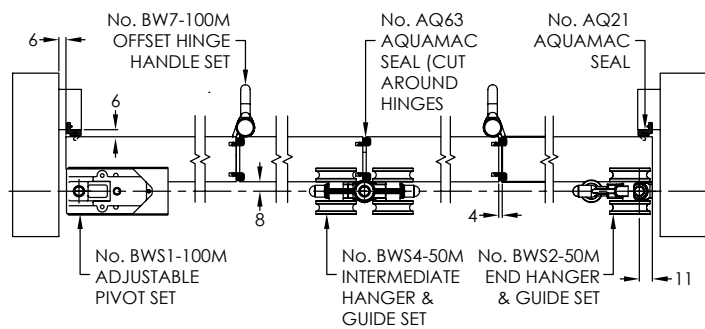

4+0 PANEL OUTWARD OPENING SYSTEM - OPEN
(SHOWN WITHOUT HEAD SECTION)

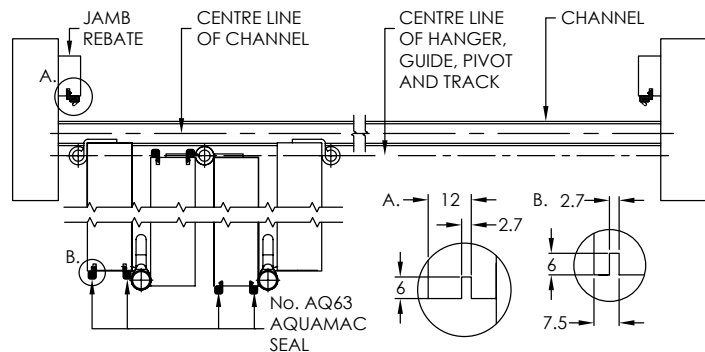

4+0 PANEL OUTWARD OPENING SYSTEM - CLOSED
(TYPICAL OUTSIDE ELEVATION)

