

DOOR CLOSERS

BTS 80

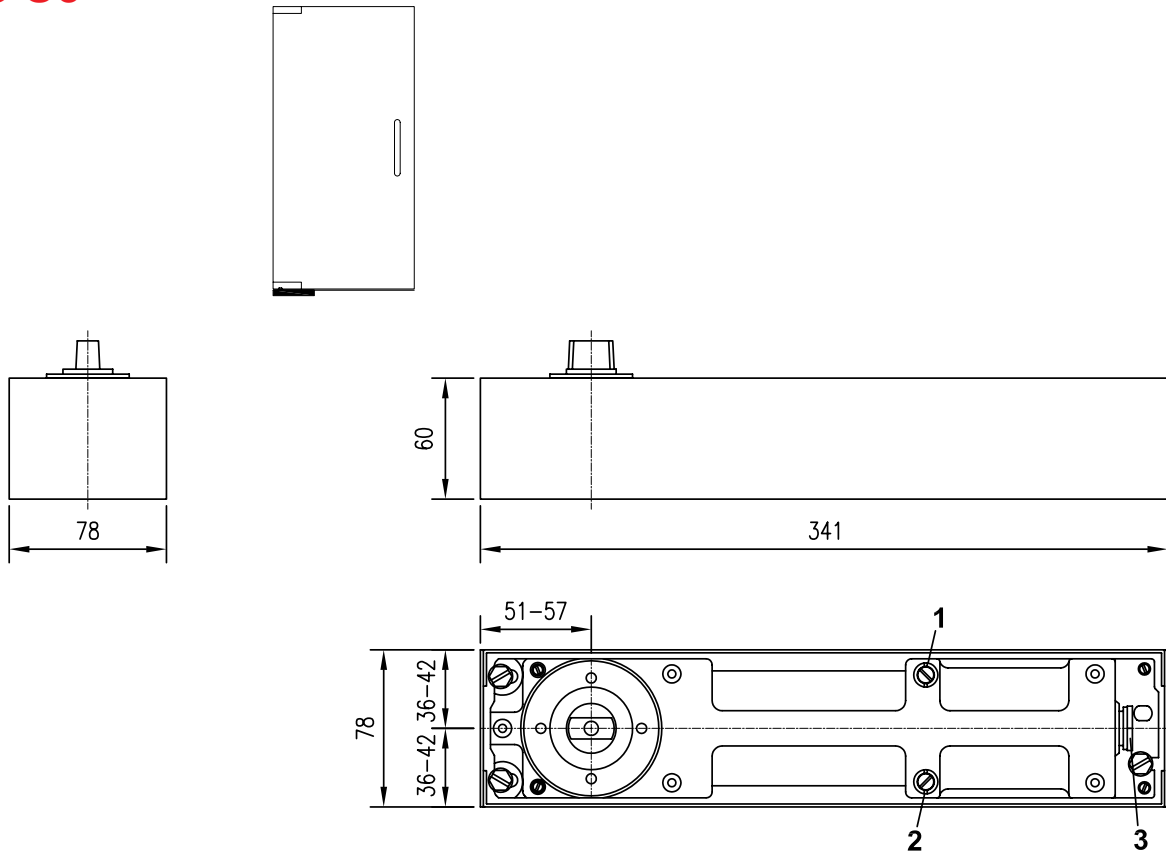

1. Adjustable closing speed
2. Hold-open range or delayed action range
3. Adjustable range - point at which hold-open begins, or end of delayed action range (approx. 75° to 105°).
4. Mechanical backcheck (from approx. 80°)

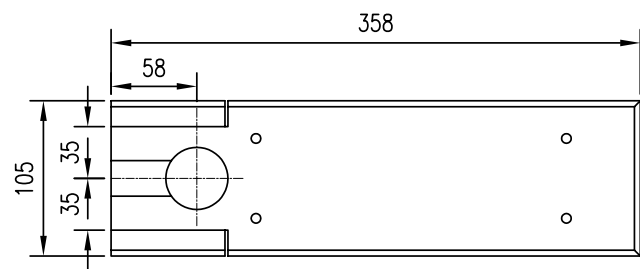
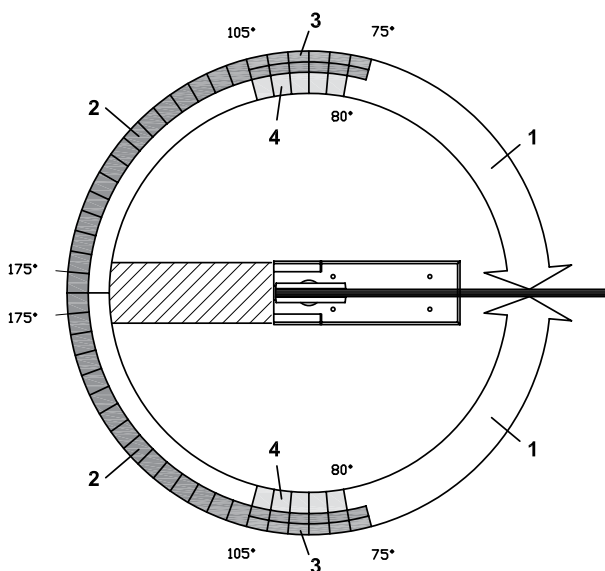

7410 COVER PLATE

BTS 80 SPECIFICATION: DORMA BTS 80 Heavy Duty Floor Spring, suited to doors up to 300kg's in weight and 1400mm wide. Floor Spring includes engageable Hold Open as standard. Specify: BTS 80 - EN3 Spring Strength, Engageable Hold Open
 BTS 80 - EN4 Spring Strength, Engageable Hold Open
 BTS 80 - EN6 Spring Strength, Engageable Hold Open

7410 FINISHES
 STAINLESS: SSS, PSS